

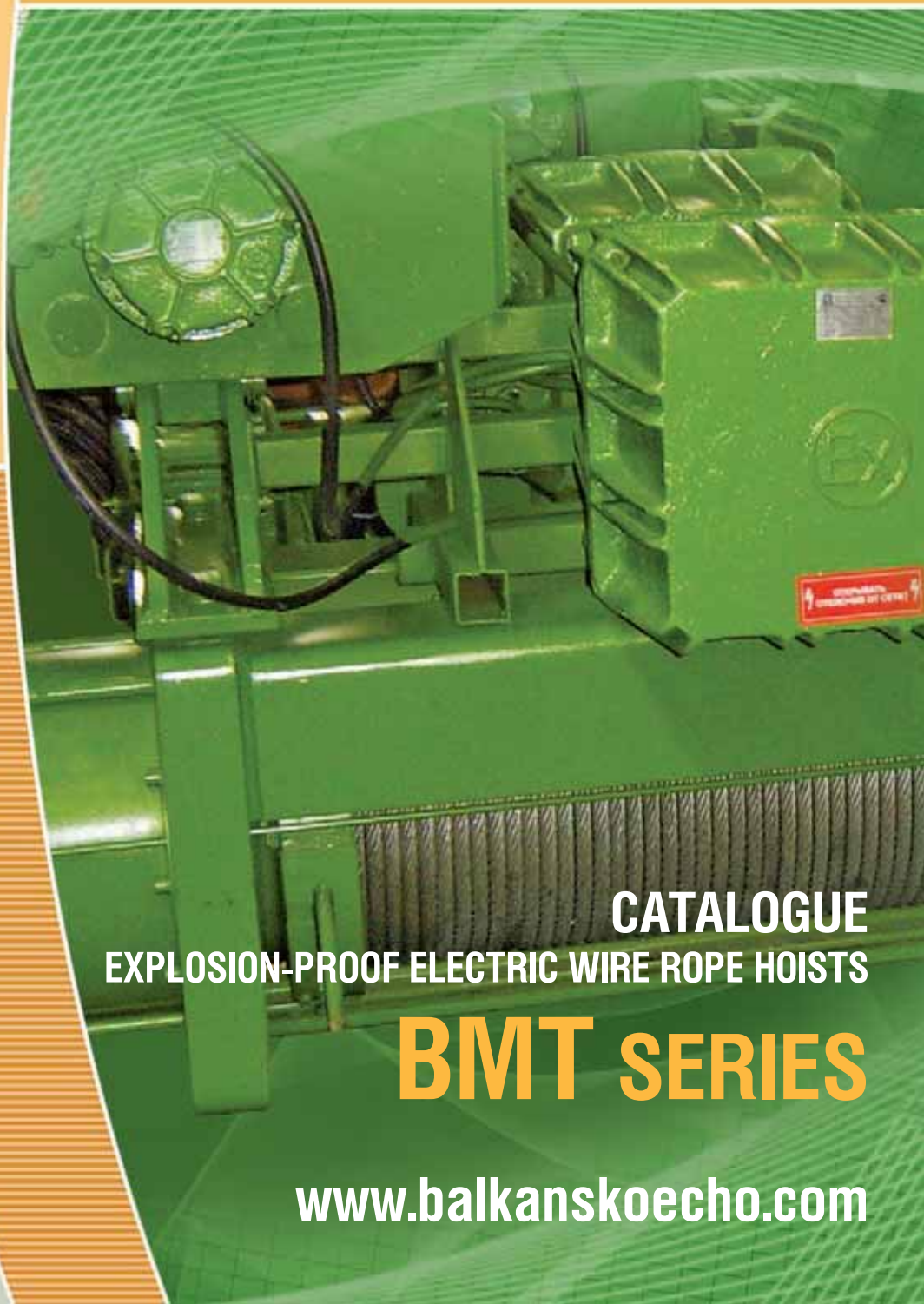

BALKANSKO ECHO

BULGARIA

PRODUCTION OF
ELECTRIC HOISTS, ELECTRIC MOTORS,
CRANES AND CRANE COMPONENTS



CATALOGUE
EXPLOSION-PROOF ELECTRIC WIRE ROPE HOISTS

BMT SERIES

www.balkanskoecho.com



BALKANSKO ECHO



THE COMPANY

Dear customers, colleagues and friends,

In front of you is the catalogue which contains valuable and useful information about the manufacturing activity and high-quality production of one of the leading companies for travel and hoist systems worldwide.

“Balkansko Echo” company is unique with its three separate factories situated on a total manufacturing area of over 20 000 m², more than 600 metal-working machines and more than 550 dedicated and highly qualified specialists, as all this makes the company independent from outer subcontractors and cooperative deliveries.

The company is designing, constructing, manufacturing, assembling and servicing the following:

- electric wire rope hoists of “T” and “MT” series with a lifting capacity of up to 50 t and a lifting height of up to 120 m, which are to be known for their exceptional reliability and durability;
- electric chain hoists, with a lifting capacity from 0,125 t to 2 t;
- single and double girder electric traveling cranes with a control from the cabin and from the ground with a lifting capacity of up to 100 t;
- bracket electric cranes with a lifting capacity from 1t to 10 t and outrigger length of 10 m;
- induction cone hoist motors, single and double- speeded, with a built-in brake and a thermo-protection from 0,12 kW to 30 kW;
- induction, mono-phase and three-phase cylindrical electric motors from 0,55 kW to 37 kW;
- geared motors for setting in motion the running gears of travel and hoist systems;
- lifting capacity limiting devices for all kinds of hoists and crane travel and hoist systems;
- complete spare parts range for all products.

All company’s products are manufactured in a general-industry, fire-safe and explosion-proof execution, and they can operate in different climate zones, including chemically aggressive environment.

The company’s system for quality management and control has been certified according to ISO 9001:2008 by TÜV Rheinland.

The company’s production has been certified according to the requirements of the countries where it is used.

By the end of 2010, “Balkansko Echo” had manufactured and sold more than 20 000 electric hoists, including 5000 explosion-proof ones, more than 600 cranes and over 50 000 general-industry and explosion-proof electric motors.

The production of “Balkansko Echo” company proves every day its high-tech qualities, security and reliability in different countries, like Russia, Kazakhstan, Belarus, Ukraine, Czech Republic, Slovakia, Turkey, Iran, etc. We are proud to announce that our goods are the only ones in the world with a 36-month warranty.

The aim of this catalogue is to provoke your interest to the goods we manufacture with great responsibility.

By this catalogue we would like to turn to you, our customers, and declare our willingness to make the most suitable product for your manufacturing, and also to assure you that you’ll make the best choice.

Please use the following telephone numbers for a twenty-four-hour contact with us: +35967302220; +359885000555; +359888223344 or you can write to us at balkanskoeho@abv.bg

ELECTRIC WIRE ROPE HOISTS

The electric wire rope hoists **BMT series** are based on the basic technical decisions that are used in BT series. By keeping the main technical features and thanks to the use of a new body construction, contemporary steel ropes, hooks, etc., we offer our customers a series of electric wire rope hoists which have got much more opportunities regarding lifting capacity, lift speed and conveying speed. This provides new possibilities for a more efficient operation of our goods.

Both series have got identical electrical equipment which defines the identity of the explosion-proof execution and marking: **(Ex) d IIB T5 and (Ex) d IIC T5**, where:

CATALOGUE EXPLOSION-PROOF ELECTRIC WIRE ROPE HOISTS

CLASSIFICATION OF EXPLOSIVE GASES

BY GROUPS AND CLASS OF TEMPERATURE

Groups	Gas	Ignition temperature, °C	Class of temperature					
			T1	T2	T3	T4	T5	T6
I	methane (marsh gas)							
II	A	acetone	540	X				
		acetic acid	485	X				
		ammonia	630	X				
		ethane	515	X				
		methylene chloride	556	X				
		methane (CH4)	595	X				
		carbon monoxide	605	X				
		propane	470	X				
		benzene	555	X				
		naphthalene	540	X				
		ethyl chloride	510	X				
	B	n-butane	365		X			
		n-butyl	370		X			
		sulfide	270			X		
		n-hexane	240			X		
		acetaldehyde	140				X	
		ether	170				X	
		ethyl nitrate	90					X
	C	ethylene	425		X			
ethylene oxide		429-440		X				
C	acetylene (C2H2)	305		X				
	carbon disulphide	102					X	
	hydrogen (H2)	560	X					

(Ex) - marking for an electric equipment which prevents from a possible ignition of the surrounding explosively hazardous environment;

d - explosion proof shield - all equipment elements that are possibly to ignite the surrounding explosively hazardous environment are placed in a shield that can sustain the gas pressure received by the explosion of hazardous mixtures inside of it, while at the same time, the hot gases pass through the so called "blast ways" (windage between the parts) and cool down to a safe temperature.

IIB - group of explosive gases;

T5 - class of temperature showing the maximum temperature on the outer surfaces that could be reached.

Technical data:

Voltage: 380 - 400V (special executions- by request)

Frequency: 50 Hz (special executions- by request)

Operational voltage: 24V, (42V)

Class of protection IP54 (EN 60529)

Operational conditions *

- climate - normal, tropical or marine
- normal or chemically aggressive environment
- temperature of the environment
 - 1) normal: from -25°C to +40°C
 - 2) low: from -40°C to +40°C
- relative air humidity- 80% at 20°C
- in closed rooms or in the open air under a shelter at normal fire-hazard

* special execution by a request

STRUCTURE

The electric hoists are based on a module construction consisting of the following elements:

1. REDUCTION GEAR

The two-stepped planetary reduction gear is positioned out of the roll or the body of the hoist.

The solid construction allows a reliable torque transmission towards the roll of the machine. The use of high-quality materials during the manufacturing process of the reduction gear is a guarantee for its reliable performance. Its positioning allows an easy service during the period of use.

2. TOOTHED CLUTCH

A construction that allows safe transmission of the motor torque to the reduction gear shaft, with sufficient possibility for axial and angle compensation- all this guarantees a normal and safe performance of the machine.

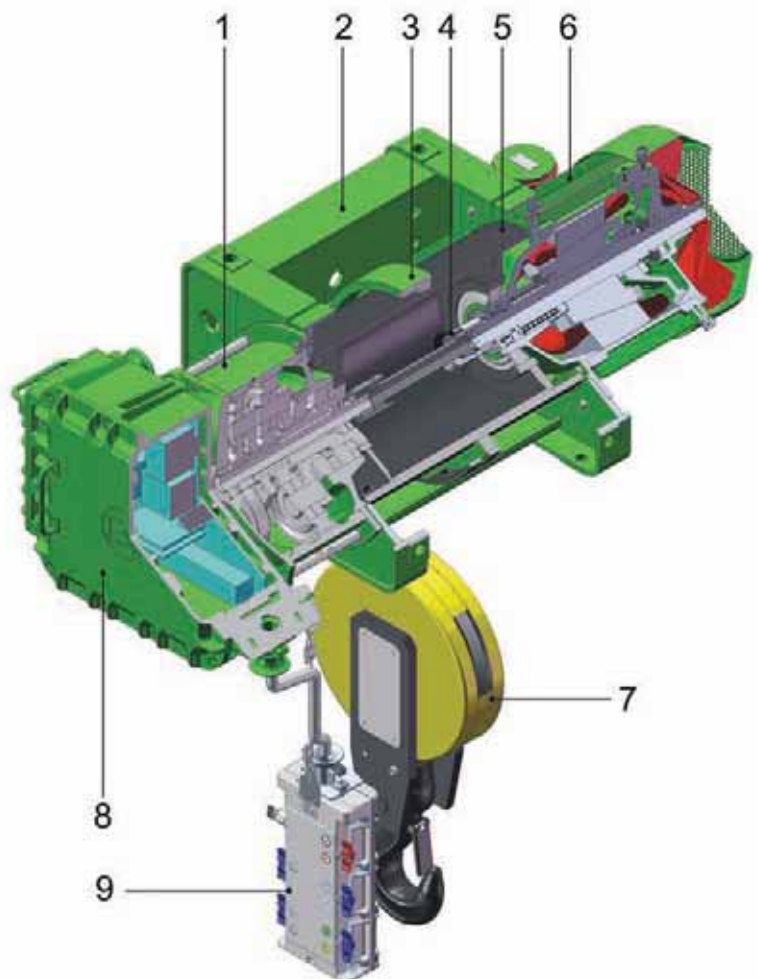

STRUCTURE

3. ROLL

The roll is positioned axle-like to the reduction gear and the electric motor. It has got ball bearings at the front guards of the electric motor and the reduction gear. It has also been designed with a screw channel for positioning the rope, according to DIN 15020.

4. BODY

It's a steel-welded construction with a prism form made of bended profiles.

The construction has got a sufficient strength and allows being realized different kinds of reeving systems, different kinds of suspensions and executions without the use of additional elements.

5. ROPE LEAD

The rope lead ensures the correct arrangement and lead of the rope in the screw channel of the roll, and also its normal going out of it. Apart this, it also functions for operating the cut-offs of the lifting mechanism, which are fixing the end up and end down position of the hook.

6. LIFTING ELECTRIC MOTOR

It's a three-phase induction motor with a cone rotor and a built-in brake. Typical for it is its simple construction giving it a great reliability and maintainability. The completely automatic brake allows safe hold of the load. It's is simple in service and adjustment during the process of operation.

Class of protection IP54, IP22 (EN 60529) for the brake; class of insulation F (H- by agreement with the customer).

We can also offer double-speeded executions with a ratio of micro-speed : main-speed- 1:4; 1:6, or stepless ones by request. All electric motors are equipped with a coil overheating protection.

In the electric motor's terminal box there is a built-in stop of the end hook positions.

7. HOOK

The hook construction and the roller block of the reeving are performed according to the requirements of DIN 15400.

8. CONTROL BLOCK

The control block consists of a body with two explosion-proof chambers marked by: (Ex) d IIB T5 or (Ex) d IIC T5. The electric appliances are positioned in the first one, and the input devices are positioned in the second one. The body, its chambers and covers are made of cast-iron moulding with sufficient strength to prevent leakage of hot gases into the explosively hazardous environment.

9. CONTROL DESK

It is an explosion-proof shield marked by (Ex) d IIB T5 or (Ex) d IIC T5, and it is manufactured from aluminum alloy that prevents formation of friction sparks.

SINGLE-GIRDER TROLLEY

Normal and reduced headroom execution. They are being driven by electric motors with cone rotor and an automatic cone brake, single and double-speeded (ratio 1:3, and stepless also by request), class of protection IP54, class of insulation F. These can be driven on rectilinear and curve sections, onto single girder roads with 90...300 mm in width.

DOUBLE-GIRDER CRANE TROLLEY

Executions in a variety of lifting capacity, driven by one or two gearmotor groups, equipped with electric motors with cone rotor and an automatic cone brake, single and double-speeded (ratio 1:3, and stepless also by request), class of protection IP54, class of insulation F. Great variety of girder wheel-base length (1000 -2800 mm).



CATALOGUE EXPLOSION-PROOF ELECTRIC WIRE ROPE HOISTS

STANDARD EXECUTIONS

Stationary

Lifting capacity: 400 – 32 000 kg

special executions- to 63 000 kg

Reeving: 1/1; 2/1; 4/1; 2/2; 4/2

special executions- 6/1; 8/1; 2x2/1-1; 2x3/1-1; 2x4/1-1

Lift height: 4.5 – 104 m

Lift speed: 1- 20 m/min (by microscope at a rate of 1:4)

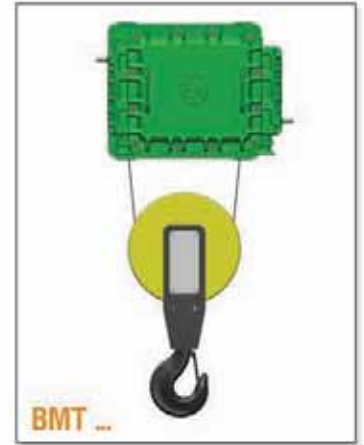

With a single-girder trolley (normal headroom height)

Capacity: 400 – 20 000 kg

Reeving: 2/1; 4/1; 4/2; 2x2/1-1

special executions- 1/1; 2/2;

Lift height: 4.5 – 60 m

special executions- to 120 m

Lift speed: 1- 20 m/min
(by microscope at a rate of 1:4)

Convey speed:

8; 10; 12; 20; 12/4; 15/5; 20/6; 32/10 m/min

With a single-girder trolley (reduced headroom height)

Lifting capacity: 400 – 16 000 kg

special executions- to 20 000 kg

Reeving: 1/1; 2/1; 4/1

special executions- 4/2

Lift height: 4.5 – 60 m

Lift speed: 1- 20 m/min (by microscope at a rate of 1:4)

Convey speed:

8; 10; 12; 20; 12/4; 15/5; 20/6; 32/10 m/min

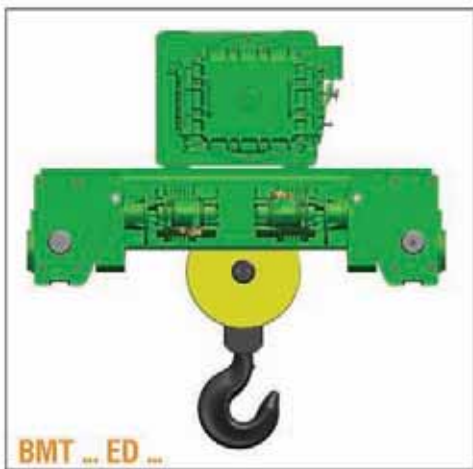

With a double-girder trolley

Lifting capacity: 1000 – 32 000 kg

special executions- to 63 000 kg

Reeving: 1/1; 2/1; 4/1; 2/2; 4/2

special executions- 6/1; 8/1; 2x2/1-1; 2x3/1-1; 2x4/1-1

Lift height: 4.5 – 60 m

special executions- to 120m

Lift speed: 1- 20 m/min

(by microscope at a rate of 1:4)

special executions- 32 m/min

Convey speed:

8; 10; 12; 15; 20; 32; 40 m/min

(by microscope at a rate of 1:3)

Gauge: 1 000- 2 800 mm

CATALOGUE EXPLOSION-PROOF ELECTRIC WIRE ROPE HOISTS

REEVING SYSTEM

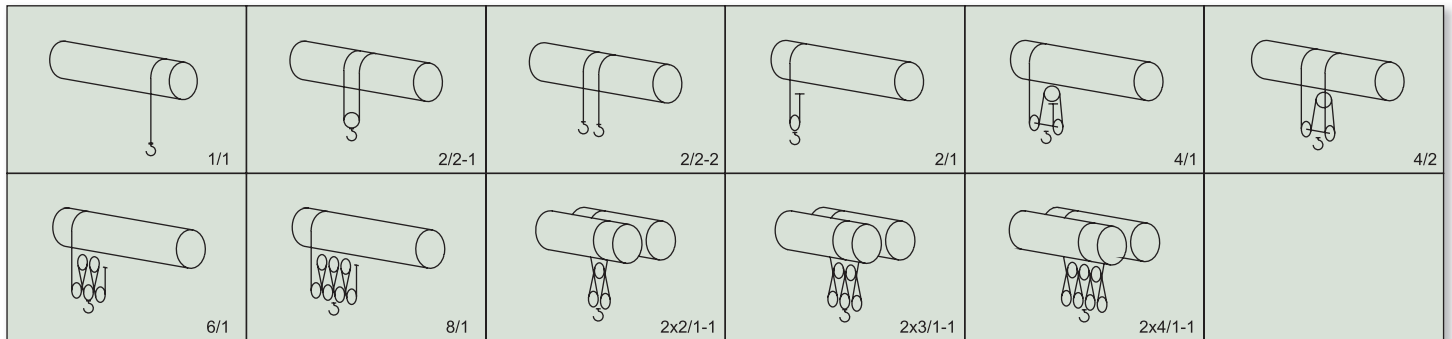

MODE OF FIXTURE

1. Hung
2. Stand
3. Side-fixed

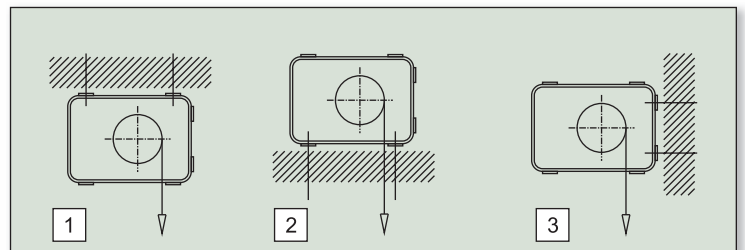

CRITERIA FOR THE CHOICE

In order to be able to make the right choice of a lifting device you need to know:

1. The maximum load that is going to be uplifted.
2. The maximum height of the lift.
3. The necessary speed of the lift.
4. The operational conditions.
5. The group and class of temperature for the hazardous environment.

After that you need to determine the operational rate group of the lifting device according to FEM 9.511, DIN 15020, ISO 4301 or ГOCT 25835.

With regard to this you need to define in advance:

- class of loading
- class of use

The class of loading can be determined by the loading factor K, using the formula:

$$K = \frac{\sum [(Q_i / Q_{nom})^3 \cdot t_i]}{\sum t_i}, \text{ where:}$$

Q_i - load being lifted by the device for a definite time t_i

Q_{nom} - the nominal (maximum) capacity of the device

t_i - duration of operation with load Q_i

$\sum t_i$ - sum of time for device operation with load.

After that the average machine time T_m for a day is being defined:

$$T_m = 2.H.N.T / 60.V, \text{ where:}$$

H- average height of lift

N- number of cycles per hour (a cycle means: lift-pause-lift down-pause)

T- daily duration of operation

V- lift speed, m/min

The data received is used to define the operational rate group, and then you may continue with the choice of a lifting device.

EXAMPLE

Lifting capacity	-	2000 kg
Average height of lift	H	3 m
Lift speed	V	8 m/min
Reeving	-	2/1
Class of loading	-	medium
Number of cycles per hour	N	30
Daily duration of operation	T	8 h
Explosively hazard environment	-	acetylene

The average machine time per a day is calculated:

$$T_m = 2.H.N.T / 60.V = 2.2.30.8 / 60.8 = 3, \text{ h}$$

Using the table for operation range, for $T_m = 3\text{h}$ and class of loading “medium”, you can define the group of operation range for the lifting device- 2 m, according to FEM 9.511.

By knowing the needed lifting capacity of **2000 kg** and using the already defined group of operation range – **2m**, and the type of reeving - **2/1**, we can define the lifting device as type **BMT410**.

Using the table for the classification of explosive gases by groups and classes of temperature, we can define:

Group IIC, Class of temperature **T2**

Therefore, the needed electric wire rope hoist is marked by **(Ex) d IIC T5**.

CATALOGUE EXPLOSION-PROOF ELECTRIC WIRE ROPE HOISTS

NOTATION

11 BMT K TII 516 H9 V1 2/1 M EN20/6 C S

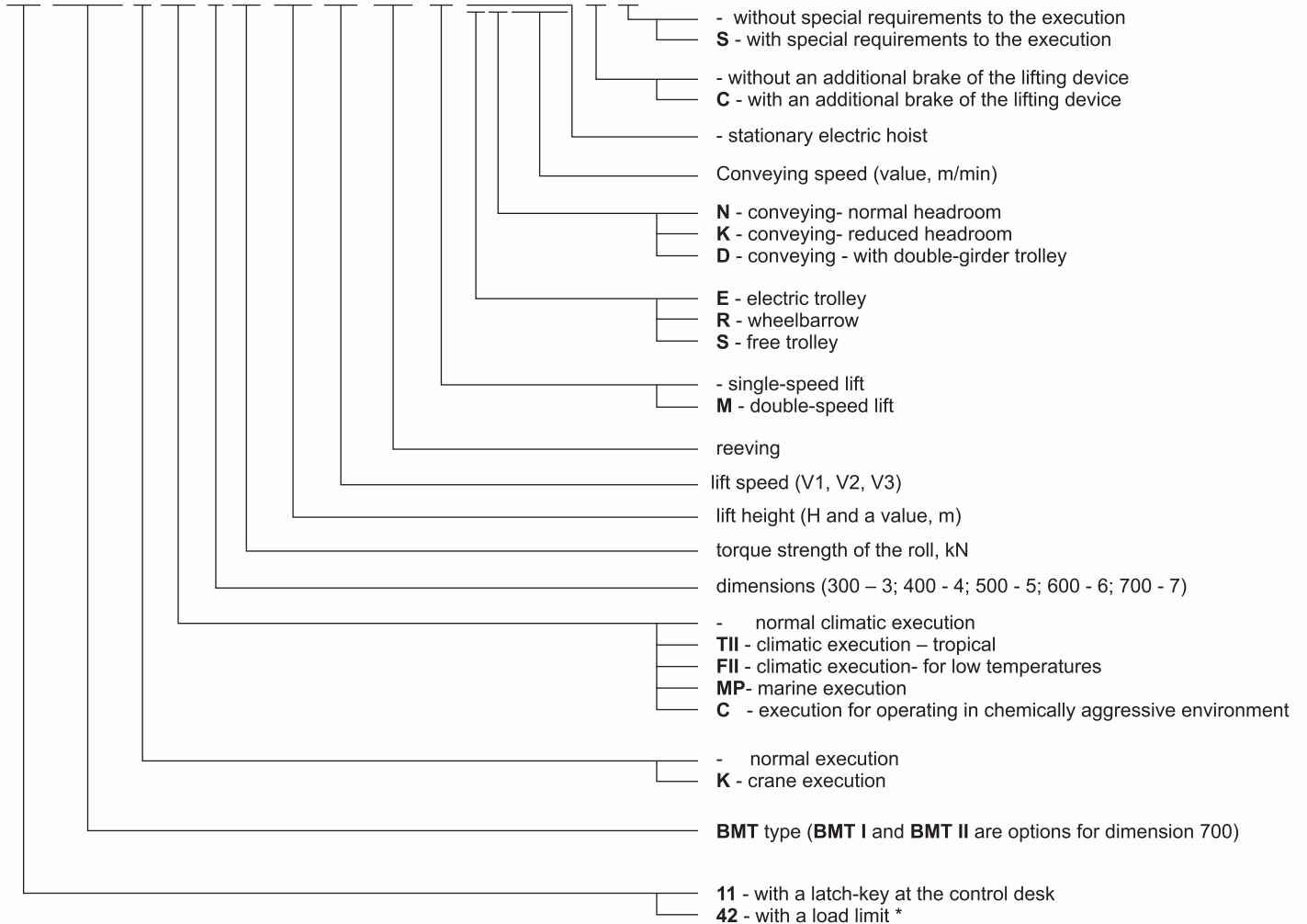

* being developed

CLASSIFICATION OF THE LIFTING DEVICES

Operation rate				Class of use			
Class of loading	Loading factor, K	Performance					
LIGHT	< 0.125	Operation with loads less than the nominal ones		$T_M, h \ 1)$			
				2-4	4-8	8-16	>16
MEDIUM	0.125 - 0.25	Operation with medium and nominal loads		$T_M, h \ 2)$			
				6 300	12 500	25 000	50 000
HEAVY	0.25 - 0.5	Operation with nominal or close to nominal loads		T_M, h			
				1-2	2-4	4-8	8-16
VERY HEAVY	0.5 - 1	Repeated operation with nominal or close to nominal loads		T_{MO}, h			
				3 200	6 300	12 500	25 000
			T_M, h				
			0,5-1	1-2	2-4	4-8	
			T_{MO}, h				
			1 600	3 200	6 300	12 500	
			T_M, h				
			0,25-0,5	0,5-1	1-2	2-4	
			T_{MO}, h				
			800	1 600	3 200	6 300	
Switching in duration, %			30	40	50	60	
Switching in frequency, h ⁻¹			180	240	300	360	
Operational rate group			FEM 9.511 / DIN15020	1Am	2m	3m	4m
			ISO 4301	M4	M5	M6	M7
			ГОСТ 25835	2M	3M	4M	5M
REEVING			DIMENSIONS	TYPE			
1/1	2/1	4/1					
LIFTING CAPACITY, kg			BMT300	-	-	-	BMT303*
320	630	1250		-	-	BMT304	-
400	800	1600	BMT400	-	BMT305	-	-
500	1000	2000		-	-	-	BMT406*
630	1250	2500	BMT500	-	-	BMT408	-
800	1600	3200		-	BMT410	-	BMT510*
1000	2000	4000	BMT600	-	-	BMT512	-
1250	2500	5000		-	BMT516	-	BMT616*
1600	3200	6300	BMT700	-	-	BMT620	-
2000	4000	8000		-	BMT625	-	BMT725*
2500	5000	10000	BMT780	-	-	BMT732	-
3200	6300	12500		-	BMT740	BMT I 740	-
4000	8000	16000		-	BMT I 750	BMT II 750	-
5000	10000	20000		-	BMT II 763	BMT763*	-
6300	12500	25000		-	-	-	-
8000	16000	32000					

* special execution by customer order

1) T_M – average machine time per day

2) T_{MO} – total time for the complete operational period

CATALOGUE EXPLOSION-PROOF ELECTRIC WIRE ROPE HOISTS

TECHNICAL DATA

LIFTING CAPACITY kg	REEVING 1/1 – 2/2 ¹⁾						
	TYPE	DIN 15020 FEM 9.511	LIFT HEIGHT, m		SPEED HEIGHT, m/min		
			1/1	2/2	V1	V2 ²⁾	V3 ²⁾
400	BMT304	3m	12;20;26;40;54;76;84	8;12.5;22;31	16	-	-
500	BMT305	2m	12;20;26;40;54;76;84	8;12.5;22;31	16	-	-
800	BMT408	3m	11;18;24;40;52;68;78	5;12;18;26	16; 4/16	-	-
1 000	BMT410	2m	11;18;24;40;52;68;78	5;12;18;26	16; 4/16	-	-
1 250	BMT512	3m	11;18;24;36;50;64;76	10;17;24	16; 2.5/10	-	-
1 600	BMT516	2m	11;18;24;36;50;64;76	10;17;24	16; 2.5/10	-	-
2 000	BMT620	3m	9;16;22;34;46;60;70;80	7;15;22;32; 37;44	16; 4/16	-	-
2 500	BMT625	2m	9;16;22;34;46;60;70;80	7;15;22;32; 37;44	16; 4/16	-	-
	BMT725	4m	18.5;29;40;54;68;81; 92;108;120.5	13;20;27;34; 39;47;53	16; 2.5/10	-	-
		3m	16;24;34;46;58;70;80 94;104	13;20;27;34; 39;47;53	16; 2.5/10	-	-
3 200	BMT732	3m	16;24;34;46;58;70;80 94;104	13;20;27;34; 39;47;53	16; 2.5/10	-	-
4 000	BMT I 740	3m	16;24;34;46;58;70;80 94;104	13;20;27;34; 39;47;53	12; 2/8	18	-
	BMT740	2m	16;24;34;46;58;70;80 94;104	13;20;27;34; 39;47;53	16; 2.5/10	24	-
5 000	BMT II 750	3m	16;24;34;46;58;70;80 94;104	13;20;27;34; 39;47;53	10	15	18
	BMT I 750	2m	16;24;34;46;58;70;80 94;104	13;20;27;34; 39;47;53	12; 2/8	15	18
6 300	BMT II 763	2m	16;24;34;46;58;70;80 94;104	13;20;27;34; 39;47;53	10	15	-
8 000	BMT780	1Am	16;24;34;46;58;70;80 94;104	13;20;27;34; 39;47;53	8	12	-

1) Refers only to stationary wire rope hoists, without any limit of load
2) 1) Being developed

TECHNICAL DATA

LIFTING CAPACITY kg	REEVING 2/1 – 4/2						
	TYPE	DIN 15020 FEM 9.511	LIFT HEIGHT, m		SPEED HEIGHT, m/min		
			2/1	4/2	V1	V2 ¹⁾	V3 ¹⁾
800	BMT304	3m	6;10;13;20;27;38;42	6.5;11;15.5	8	-	-
1 000	BMT305	2m	6;10;13;20;27;38;42	6.5;11;15.5	8	-	-
1 600	BMT408	3m	5.5;9;12;20;26;34;39; 47;52;60	6;9;13	8; 2/8	-	-
2 000	BMT410	2m	5.5;9;12;20;26;34;39; 47;52;60	6;9;13	8; 2/8	-	-
2 500	BMT512	3m	5.5;9;12;18;25;32;38 43;49	5;8.5;12	8; 1.25/5	-	-
3 200	BMT516	2m	5.5;9;12;18;25;32;38 43;49	5;8.5;12	8; 1.25/5	-	-
4 000	BMT620	3m	4.5;8;11;17;23;30;35; 40;46;54;60	3.6;8.5;11; 16;18.5;22	8; 2/8	-	-
5 000	BMT625	2m	4.5;8;11;17;23;30;35; 40;46;54;60	3.6;8.5;11; 16;18.5;22	8; 2/8	-	-
	BMT725	4m	14.5;20;27;34;40.5; 46;54;60	6.5;10;13.5;17; 19.5; 23.5;26.5	8; 1.25/5	12	-
		3m	12;17;23;29;35;40; 47;52	6.5;10;13.5;17; 19.5; 23.5;26.5	8; 1.5/6	12	-
6 300	BMT732	3m	12;17;23;29;35;40; 47;52	6.5;10;13.5;17; 19.5; 23.5;26.5	8; 1.25/5	12	-
8 000	BMT I 740	3m	12;17;23;29;35;40; 47;52	6.5;10;13.5;17; 19.5; 23.5;26.5	6; 1/4	9	-
	BMT740	2m	12;17;23;29;35;40; 47;52	6.5;10;13.5;17; 19.5; 23.5;26.5	8; 1.25/5	12	-
10 000	BMT II 750	3m	12;17;23;29;35;40; 47;52	4.5;7.5;10.5 15.5;19.5; 22	5	7.5	9
	BMT I 750	2m	12;17;23;29;35;40; 47;52	6.5;10;13.5;17; 19.5; 23.5;26.5	6; 1/4	7.5	9
12 500	BMT II 763	2m	12;17;23;29;35;40; 47;52	4.5;7.5;10.5 15.5;19.5; 22	5	7.5	-
16 000	BMT780	1Am	12;17;23;29;35;40; 47;52	4.5;7.5;10.5 15.5;19.5; 22	4	6	-

1) Being developed

CATALOGUE EXPLOSION-PROOF ELECTRIC WIRE ROPE HOISTS

TECHNICAL DATA

LIFTING CAPACITY kg	REEVING 4/1					
	TYPE	DIN 15020 FEM 9.511	LIFT HEIGHT, m	SPEED HEIGHT, m/min		
				V1	V2 ¹⁾	V3 ¹⁾
1 600	BMT304	3m	6.5;10;13.5	4	-	-
2 000	BMT305	2m	6.5;10;13.5	4	-	-
3 200	BMT408	3m	6;10;13	4; 1/4	-	-
4 000	BMT410	2m	6;10;13	4; 1/4	-	-
5 000	BMT512	3m	6;9;12.5	4; 0.63/2.5	-	-
6 300	BMT516	2m	6;9;12.5	4; 0.63/2.5	-	-
8 000	BMT620	3m	5.5;8.5;11.5;15;17.5;20	4; 1/4	-	-
10 000	BMT625	2m	5.5;8.5;11.5;15;17.5;20	4; 1/4	-	-
	BMT725	4m	10;13.5;17;20; 23; 27; 30	4; 0.63/2.5	6	-
		3m	8.5;11.5;14.5;17.5; 20; 23.5; 26	4; 0.63/2.5	6	-
12 500	BMT732	3m	8.5;11.5;14.5;17.5; 20; 23.5; 26	4; 0.63/2.5	6	-
16 000	BMT I 740	2m	8.5;11.5;14.5;17.5; 20; 23.5; 26	3; 0.5/2	4.5	-
	BMT740	2m	8.5;11.5;14.5;17.5; 20; 23.5; 26	4; 0.63/2.5	6	-
20 000	BMT II 750	3m	8.5;11.5;14.5;17.5; 20; 23.5; 26	2.5	3.75	4.5
	BMT I 750	2m	8.5;11.5;14.5;17.5; 20; 23.5; 26	3; 0.5/2	3.75	4.5
25 000	BMT II 763	2m	8.5;11.5;14.5;17.5; 20; 23.5; 26	2.5	3.75	-
32 000	BMT780	1Am	8.5;11.5;14.5;17.5; 20; 23.5; 26	2	3	-

1) Being developed

TECHNICAL DATA - SPECIAL EXECUTIONS

LIFTING CAPACITY kg	REEVING 6/1					
	TYPE	DIN 15020 FEM 9.511	LIFT HEIGHT, m	SPEED HEIGHT, m/min		
				V1	V2	V3
25 000	BMT I 740	3m	5.5; 7.5; 9.5; 11.5; 13; 15.5; 17	2; 0.32/1.25	3	-
32 000	BMT II 750	3m	5.5; 7.5; 9.5; 11.5; 13; 15.5; 17	1.6	2.5	3
	BMT I 750	2m	5.5; 7.5; 9.5; 11.5; 13; 15.5; 17	1.6; 0.32/1.25	2.5	3
40 000	BMT II 763	2m	5.5; 7.5; 9.5; 11.5; 13; 15.5; 17	1.6	2.5	-
50 000	BMT780	1Am	5.5; 7.5; 9.5; 11.5; 13; 15.5; 17	1.3	2	-

BMT SERIES

LIFTING CAPACITY kg	REEVING 8/1					
	TYPE	DIN 15020 FEM 9.511	LIFT HEIGHT, m	SPEED HEIGHT, m/min		
				V1	V2	V3
32 000	BMT I 740	3m	6; 7.5; 9; 10; 12; 13;	1.5; 0.25/1	2.25	-
	BMT 740	2m	6; 7.5; 9; 10; 12; 13;	2; 0.32/1.25	3	-
40 000	BMT II 750	3m	6; 7.5; 9; 10; 12; 13;	1.25	1.8	2.25
	BMT I 750	2m	6; 7.5; 9; 10; 12; 13;	1.5; 0.25/1	1.8	2.25
50 000	BMT II 763	2m	6; 7.5; 9; 10; 12; 13;	1.25	1.8	-
63 000	BMT780	1Am	6; 7.5; 9; 10; 12; 13;	1	1.5	-

LIFTING CAPACITY kg	REEVING 2x2/1-1					
	TYPE	DIN 15020 FEM 9.511	LIFT HEIGHT, m	SPEED HEIGHT, m/min		
				V1	V2	V3
16 000	BM I T740	3m	8;12;17;23;29;35;40; 47;52	6; 1/4	9	-
	BMT740	2m	8;12;17;23;29;35;40; 47;52	8; 1.25/5	12	-
20 000	BM II T750	3m	8;12;17;23;29;35;40; 47;52	5	7.5	9
	BMT I 750	2m	8;12;17;23;29;35;40; 47;52	6; 1/4	7.5	9
25 000	BMT II 763	2m	8;12;17;23;29;35;40; 47;52	5	7.5	-
32 000	BMT780	1Am	12;17;23;29;35;40; 47;52	4	6	-

LIFTING CAPACITY kg	REEVING 2x3/1-1					
	TYPE	DIN 15020 FEM 9.511	LIFT HEIGHT, m	SPEED HEIGHT, m/min		
				V1	V2	V3
25 000	BMT I 740	3m	5.5; 8.5; 11.5; 13; 15.5; 19.5; 23.5; 26.5; 31; 35	4; 0.63/2.5	6	-
32 000	BMT II 750	3m	5.5; 8.5; 11.5; 13; 15.5; 19.5; 23.5; 26.5; 31; 35	3.2	5	6
	BMT I 750	2m	5.5; 8.5; 11.5; 13; 15.5; 19.5; 23.5; 26.5; 31; 35	3.2; 0.63/2.5	5	6
40 000	BMT II 763	2m	5.5; 8.5; 11.5; 13; 15.5; 19.5; 23.5; 26.5; 31; 35	3.2	5	-
50 000	BMT780	1Am	5.5; 8.5; 11.5; 13; 15.5; 19.5; 23.5; 26.5; 31; 35	2.6	4	-

LIFTING CAPACITY kg	REEVING 2x4/1-1					
	TYPE	DIN 15020 FEM 9.511	LIFT HEIGHT, m	SPEED HEIGHT, m/min		
				V1	V2	V3
32 000	BMT I 740	3m	8.5;11.5;14.5;17.5; 20; 23.5; 26	3; 0.5/2	4.5	-
	BMT740	2m	8.5;11.5;14.5;17.5; 20; 23.5; 26	4; 0.63/2.5	6	-
40 000	BMT II 750	3m	8.5;11.5;14.5;17.5; 20; 23.5; 26	2.5	3.75	4.5
	BMT I 750	2m	8.5;11.5;14.5;17.5; 20; 23.5; 26	3; 0.5/2	3.75	4.5
50 000	BMT II 763	2m	8.5;11.5;14.5;17.5; 20; 23.5; 26	2.5	3.75	-
63 000	BMT780	1Am	8.5;11.5;14.5;17.5; 20; 23.5; 26	2	3	-

CATALOGUE EXPLOSION-PROOF ELECTRIC WIRE ROPE HOISTS

ELECTRIC MOTOR PARAMETERS

PARAMETERS OF THE ELECTRIC MOTORS WITH A BUILT-IN BRAKE (400 V, 50 HZ)

Type	Lifting capacity, kg	Group by FEM 9.511	Single-speed lift						Double-speed lift					
			V1		V2		V3		V1		V2		V3	
			P _H , kW	I _H , A	P _H , kW	I _H , A	P _H , kW	I _H , A	P _H , kW	I _H , A	P _H , kW	I _H , A	P _H , kW	I _H , A
BMT305	1000	2m	1.5	5.8	-	-	-	-	-	-	-	-	-	-
BMT410	2000		3.0	9.0	-	-	-	-	0.75/3.0	6.5/7.5	-	-	-	-
BMT516	3200		4.5	12.5	-	-	-	-	0.75/3.0	6.5/7.5	-	-	-	-
BMT625	5000		8.0	20.0	-	-	-	-	1.7/8.0	15.0/18.0	-	-	-	-
BMT740	8000		13	26.0	-	-	-	-			-	-	-	-
BMTI750	10000				20	38	20	38	-	-	-	-	-	-
BMTII763	12500		1Am	20	38	-	-	-	-	-	-	-	-	-
BMT780	16000	-				-	-	-	-	-	-	-	-	-

PARAMETERS OF THE ELECTRIC MOTORS WITH A BUILT-IN BRAKE FOR MONORAIL HOIST RUNNING GEARS (400 V, 50 HZ)

Type	Lifting capacity, kg		Group by FEM 9.511	Lifting height, m		Conveying speed, m/min			
	2/1	4/1		2/1	4/1	8,10,12, 20		4/12, 5/15, 6.5/20, 10/32*	
						P _H , kW	I _H , A	P _H , kW	I _H , A
BMT305	1000	2000	2m	6,10,13	6.5	0.12	0.75	0.06/0.18	1.3/0.8
BMT410	2000	4000		5.5,9,12	6	0.25	1.1	-	-
BMT516	3200	-		5.5,9,12	-				
	-	6300		-	6	0.55	1.6	0.25/0.75	3.0/2.4
BMT625	5000	-		4.5,8,11	-				

* exceptional for BMT 516 (4x1) and BMT625

Type	Lifting capacity, kg		Group by FEM 9.511	Lifting height, m		Conveying speed, m/min			
	2/1	4/1		2/1	4/1	8,10,12, 20		4/12, 5/15, 6.5/20, 10/32*	
						P _H , kW	I _H , A	P _H , kW	I _H , A
BMT305	1000	-	2m	20,27,38,42	-	2x0.12	0.75	2x0.06/0.18	1.3/0.8
	-	2000		-	10,13.5				
BMT410	2000	4000		20,26,34,39,47,52,60	10,13	2x0.25	1.2	-	-
BMT516	3200	6300		18,25,32,38,43,49	9,12.5				
BMT625	5000	-		17,23,30,35,40,46,54,60	-				
	-	10000		-	5.5,8.5,11.5 15,17.5,20				
BMT740	8000	-		8,12,17,23,29,35,40,47,52	-	2x0.55	1.6	2x0.25/0.75	3.0/2.4
BMTI750	10000								
BMTII763	12500								

* exceptional for BMT625 (4/1) and BMT740, BMT I 750 and BMT II 763

ELECTRIC MOTOR PARAMETERS

Type	Lifting capacity, kg	Group by FEM 9.511	Lifting height, m	Conveying speed, m/min			
				8, 10, 12, 20		4/12, 5/15, 6/18, 6.5/20	
	4/1		4/1	P _H , kW	I _H , A	P _H , kW	I _H , A
BMT740	16000	2m	8.5, 11.5, 14.5 17.5, 20, 23.5, 26	2x0.55	1.6	2x0.25/0.75	3.0/2.4

WE ALSO MANUFACTURE

T- electric wire rope hoists

The electric wire rope hoists T series are the most famous and well-sold electric hoists worldwide. More than 1 800 000 pieces have already been produced and sold in more than 40 countries. Their main advantages are: high reliability, durability, simple maintenance. These advantages in combination with the broad range of weight lifting capacity, lift and convey speeds, construction executions, and ability to be used in different conditions, make the hoists of this series preferred to the other executions despite their 30-year-old history.

MT- electric wire rope hoists

The wire rope hoists of MT series are the inheritors of the world's most popular series of electric wire rope hoists T. By keeping the basic technical features and thanks to the use of a new body construction, contemporary steel ropes, hooks, etc., we offer our customers a series of electric hoists with much extended opportunities like lifting capacity, lift speed and conveying speed. All this expands new opportunities for a more efficient operation of our products.

BT- explosion-proof electric wire rope hoists

Based on the basic construction decisions of electric wire rope hoists series T and keeping its technical features, series BT electric explosion-proof wire rope hoists is intended to operate in an explosion hazardous environment.

The electrical equipment included in these goods, such as: electric motors, electric appliances panel, control panel, overtravel limit switches, etc., is manufactured in the so called "explosion-proof" execution, and it is marked by: (Ex) d IIB T5 and (Ex) d IIC T5.

Induction electric motors

1. With built-in brakes, for the main lift of electric chain and wire rope hoists and other running gears - from 0.75 kW up to 30 kW. Explosion-proof execution as an option.
2. With built-in brakes, for running gears of electric chain hoists and wire rope hoists and other lifting parts - from 0.12 kW to 3 kW. Explosion-proof execution as an option.
3. Electric motors for general purposes, executions of IM B3, IM B5, IM b35, IM B14, etc., with or without a built-in brake - from 0.55 kW to 37 kW.

Weight-lifting cranes

1. Single-girder underslung traveling cranes - lifting capacity from 1 to 16 t and a span from 3 to 25 m.
2. Single-girder stationary traveling cranes - lifting capacity from 1 to 16 t and a span from 4.5 to 25.5 m.
3. Double-girder stationary traveling cranes - lifting capacity from 5 to 100 t and a span from 10.5 to 50 m.
4. Bracket stationary and wall-mounted cranes - lifting capacity from 1 to 10 t and an outrigger spread from 3 to 10 m. Ground and cabin control. Explosion-proof execution as an option.

Crane components

1. Reduction gears and geared motor groups - intended for driving the running gears of girder cranes and other lifting equipment. These are available in a great variety of output revolutions and torques. They are driven by electric motors with built-in cone brakes. Explosion-proof execution as an option.
2. Front girders for stationary traveling cranes - diameters of traveling wheels from 160 to 400 mm, load of the traveling wheel from 4000 to 19 500 kg, conveying speeds from 8 to 32 m/min. Explosion-proof execution as an option.
3. Cable trolleys - intended for carrying supply and operation cables of traveling cranes. Available in executions for traveling onto profile or straight steel rope.



BALKANSKO ECHO

**“BALKANSKO ECHO” EOOD
Bulgaria**

**5460 Kravenik village, municipality Sevlievo,
region Gabrovo**

tel.: +359 67302 220

fax: +359 67302 375

e-mail: balkanskoecho@abv.bg

www.balkanskoecho.com

